

Single Channel Mass Flow or Point Level Switch

Features

- Mass flow Switch for the detection of the mass flow rate of liquids and gases
- Point level switch for liquid level detection
- Wide operating temperature range -100F to +850F (-70C to 458C)
- Flow Switch range of 0.01 to 5 fps liquids and 0.1 to 500 fps gases
- Level Switch switches on level change 0.03 inch
- Fast flow switch response time of 0.5 to 10 seconds (media dependent)
- Level switch response time of 0.1 to 1 second of wetting (media dependent)
- CE, CENELEC and CSA approvals

SIERRA
INSTRUMENTS, INC.
THE MASS FLOW COMPANY

5 Harris Court, Bldg. L
Monterey CA 93940
831/373-0200
800/866-0200
FAX: 831/373-4402
www.sierrainstruments.com



Innova-Switch™



Description

Sierra Instruments' Innova-Switch represents the State-of-the-art in gaseous and liquid flow switching or liquid level control and continues the Sierra tradition of providing the highest quality mass flow meters and controllers in the industry.

Flow and level detection is accomplished by using a high-resolution thermal differential technique. The sensor consists of a pair of matched Resistance Temperature Detectors (RTD's). One RTD is self-heated using a constant DC current. The other RTD is unheated and provides an accurate process temperature reference. The thermal differential created between the reference and the heated RTD pair is a function of the density and/or velocity of the media with which the sensor is in contact.

The sensor and wetted parts are of durable 316L stainless steel, all welded construction with no moving parts. The switch is easy to install and adjust, giving reliable, low maintenance performance in the most demanding applications.

Dimensional Specifications

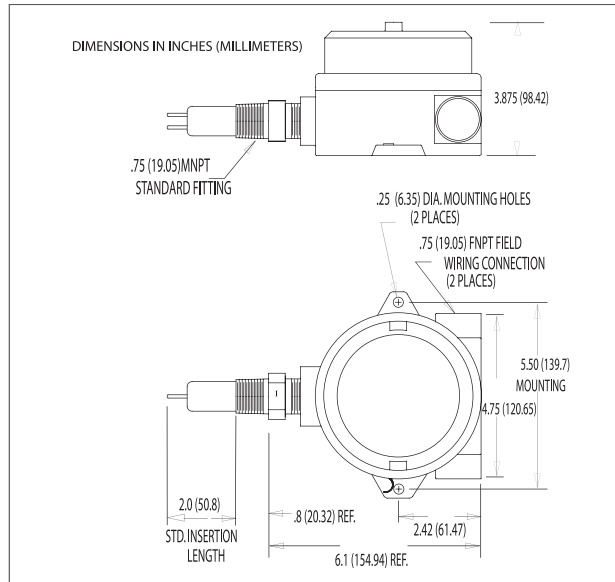

Performance Specifications

Operating Range:

Flow Switch: Adjustable flow rate (feet per second-fps), typical: 0.01 to 5.0 fps liquids and 0.1 to 500 fps gases

Level Switch: Switch on level change of 0.03 inch

Response Time:

Flow Switch: 0.5 to 10 seconds (media dependent)

Level Switch: 0.1 to 1 second (media dependent)

Repeatability: +/- 1% of setpoint (Flow) or 1/32" (0.8mm) Level

Stability: Drift <0.5% from calibrated setpoint over a range of +/-50F.

Temperature compensated through entire range.

Ordering Information

PARENT MODEL NUMBER		
LS32	Innova-Switch LEVEL Switch	
FS42	Innova-Switch FLOW Switch	
AGENCY APPROVALS		
CS	CSA approved	
CN	CENELEC approved	
PROCESS CONNECTIONS		
3A1	1.5" Sanitary with 3A stamp	
075	0.75" MNPT (STD)	
050	0.50" MNPT	
100	1" MNPT	
SENSOR MATERIAL		
HC	Hastalloy C	
S6	316SS (STD)	
S4	304SS	
SL	304L SS	
HB	Hastalloy B	
INSERTION LENGTH		
000.00	0.5" to 120" in .25" increment	
002.00	2.00" (STD)	
POWER INPUT		
24D	24 VDC	
110	110 VAC	
220	220 VAC	
CONFIGURATION		
RE	Remote Electronics	
LE	Local Electronics (STD)	
SPECIAL OPTIONS		
MT	Medium T	
HT	Hi T	
RTD	RTD output	
TO	Thermocouple output	
CA	Additional cable	
CE	CE approval	
00	No special options	
CB	Calibration Required	
EN	Extended Neck	
XW	Explosion Proof window	
V1	Variable insertion	
LT	Live (hot) tap	
DS	Double Sided	

Operating Specifications

Operating Temperature:

Process: -70C to 200C (-100F to 390F) standard. Medium T to 300C (572F) optional

Hi T to 485C (850F)

Electronics: -40C to 60C (-40F to 140F). Optional remote electronics for use in medium and Hi T environments

Operating Pressure: to 3000 psia (207 bar)

Input Power: 115 VAC, 50/60Hz standard. 230 VAC, 50/60Hz optional, 24VDC optional. 3.1 Watt maximum

Output: 5A. 250 VAC. DPDT with fail safe capability

Physical Specifications

Wetted Materials: 316 SS standard. Hastelloy, Monel, Inconel or other materials optional

Enclosure: Explosion Proof; NEMA 3,4X,7,9. CSA, FM, UL, CENELEC and EECs approved

Process Connection: 0.75" MNPT standard. 0.5" and larger MNPT and various other process connections such as sanitary and flanges optional

Insertion Length: 2.0" standard. 0.5" or greater optional

Approvals: CE, CSA, CENELEC Class 1 Div 1 Groups B,C,D