

Ultrasonic Transit-Time Flow Meter

Features

- Accuracy +/- 0.5% of reading
- Repeatability +/- 0.5% of reading
- Wide operating temperature range
-40F to 176F (-40C to 80C)
- Available with insertion high temperature transducers -40F to 300F (-40C to 150C)
- One meter for a wide range of pipe sizes from 1" to 200" (25mm to 5000mm)
- Clamp-on sensors require no pipe cutting, no plant shut-down, are a hygienic measurement leading to lower installation and labor costs
- Available with standard insertion transducers or small (0.75" diameter) insertion transducers for pipes smaller than 16" (DN 400)
- Wide bi-directional Flow range of 0 to 40 ft/s (0 to 12 m/s)
- Daily, monthly and yearly totalized flow
- Internally configured batch controller makes batch control convenient
- Measurement is independent of fluid conductivity for a wider applicability than magnetic meters
- 1 gig SD card high memory data logger



For information online: www.sierrainstruments.com

Model 205 Innova-Sonic®



Description

Our Innova-Sonic® ultrasonic flow meter is a state-of-the-art universal transit-time flow meter incorporating the latest developments in digital signal processing. Sophisticated electronics coupled with powerful ultrasonic transducers deliver highly accurate flow measurement for liquids in full pipes. While principally designed for clean liquid applications, the instrument is tolerant of liquids with the small quantity of air bubbles or suspended solids common in most industrial applications.

Innova-Sonic® offers low power consumption, high reliability, and outstanding applicability at an economical price. An easy to read display and clear, user-friendly menu selections make using the instrument simple and convenient. The instrument can be configured via keypad without any additional programming devices, is packaged in a die cast NEMA 4X (IP65) housing, and is available in your choice of non-invasive clamp-on or insertion transducer configurations.

Innova-Sonic® features a self-contained 4-20 mA current loop signal output for instantaneous flow, as well as two independent temperature inputs for thermal energy monitoring. The instrument also features a 7 digit alphanumeric display, parallel operation of positive, negative and net flow totalizers (with user-selectable scale factors) and configurable pulse and frequency outputs (transmitted via relay and open collector) for totalized flow. SD data logging capability is included and energy monitoring is fully supported at no additional charge.

Performance Specifications

Flow Range:

0 to +/- 40 ft/s (0 to +/- 12 m/s)

Accuracy:

+/- 0.5% of reading

Repeatability:

+/- 0.5% of reading

Pipe Size:

1 in to 200 in (25mm to 5000mm)

Operating Specifications

Output:

Analog: 0/4 to 20mA (max load 750Ω)
 Pulse output: 0 to 9999Hz, OCT, (min. and max. frequency is adjustable)
 Relay output: SPST, max 1Hz, (IA@125VAC or 2A @ 30VDC)
 Digital output: RS232 or RS485

Power Supply: 90 to 250 VAC, 48 to 63 Hz
 10 to 36 VDC (both are standard)

Keypad: 16 (4x4) key with tactile action

Display: 40 character, 2 line (20x2) lattice alphanumeric, backlit LCD

Temperature: Transmitter: -40F to 140F (-40C to 60C)
 Clamp-on transducer: -40F to 176F (-40C to 80C)
 Insertion transducer: -40F to 176F (-40C to 80C)
 Insertion high-temperature transducer: -40F to 300F (-40C to 150C)

Insertion Transducer Pressure:

Max operating pressure 20 barg, 300 psig

Humidity: Up to 99%RH, (non-condensing).

Physical Specifications

Transmitter: NEMA 4X (IP65), die-cast aluminum

Transducer: Encapsulated design standard/maximum cable length: 30ft/1000ft (9m/305m)

Weight Transmitter: Approximately 4.7 lb (2.15kg)
 Transducer: approximately 2.0 lb (0.9kg) (standard)

Typical Clamp-On Installation



Transmitter Dimensional Specifications

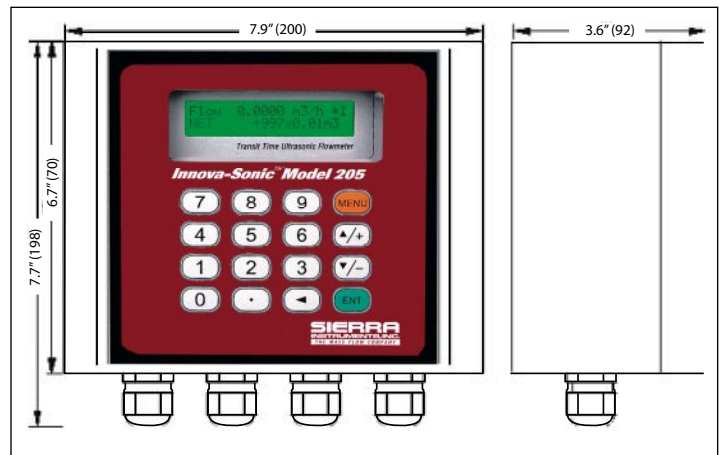

Clamp-on Transducer Dimensional Specifications

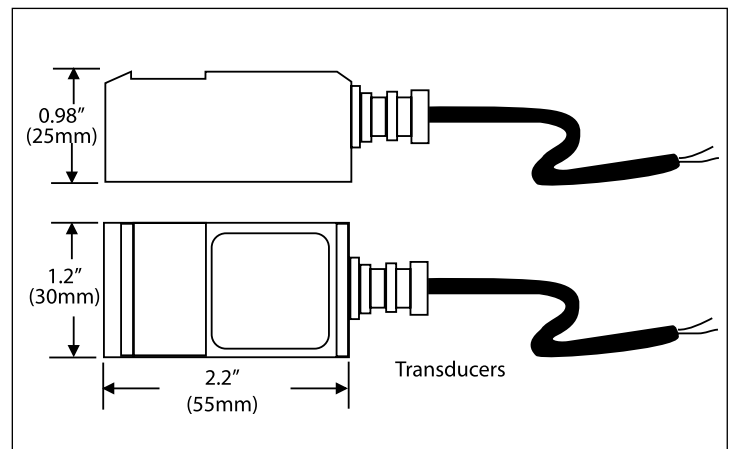

Typical Insertion Installation



Standard Insertion Transducer



Small (3/4") Insertion Transducer

Suitable Locations

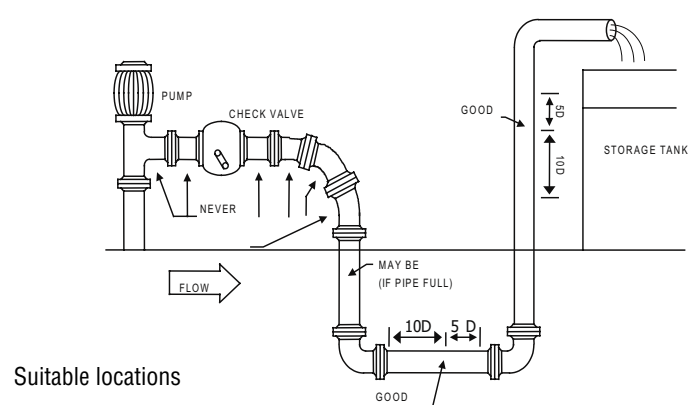
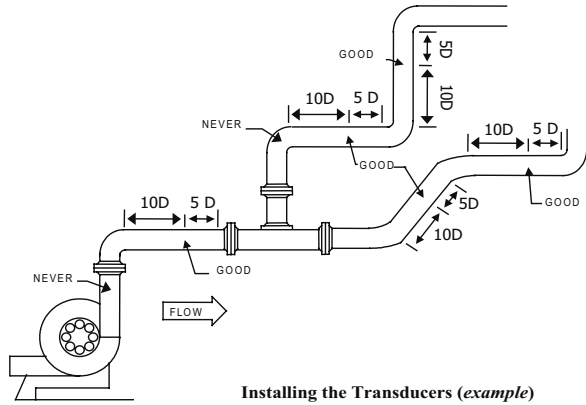

Transducer Spacing Requirements

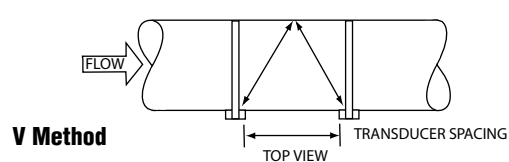
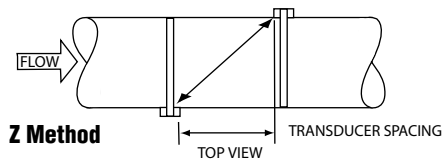
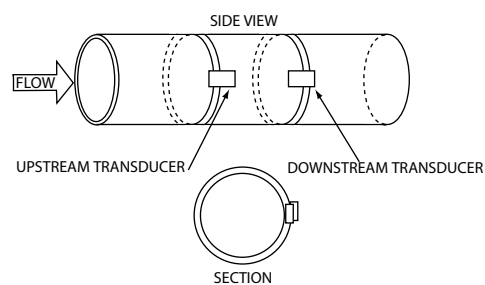
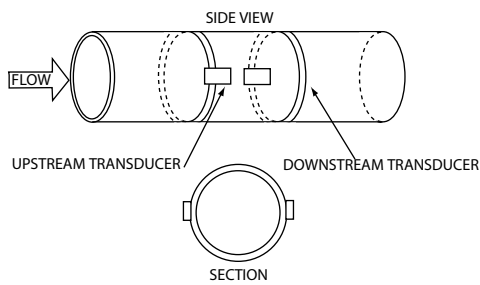

Insertion Transducer

DIMENSIONAL SPECIFICATIONS-STANDARD INSERTION SENSOR

No.	Parts	No.	Parts
1	Cable	7	Set Screw
2	End Connector	8	O-Ring
3	O-Ring	9	Nut
4	Alignment Handle	10	Ball Valve
5	Locking Sleeve	11	Mounting Collar
6	Locking Collar	12	Transducer Housing

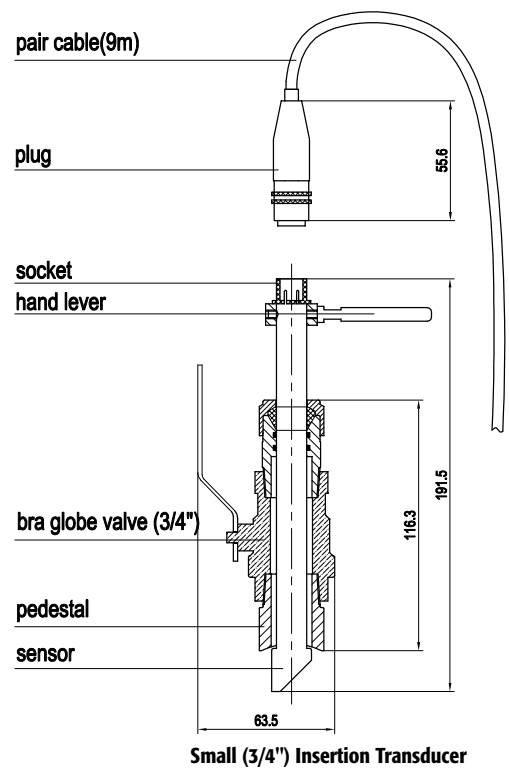
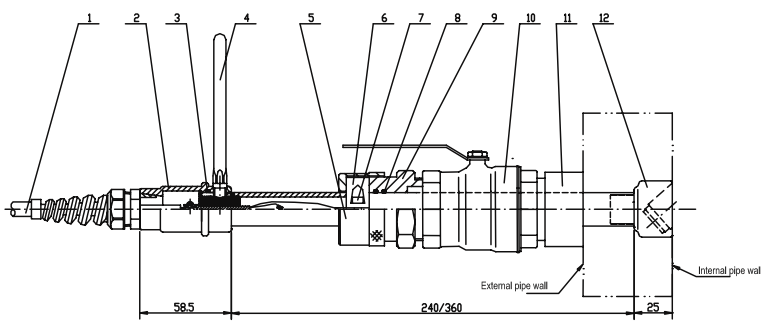

Ordering the Model 205

205

PARENT MODEL NUMBER

205 Innova-SonicT® Digital Correlation Transit Time Flowmeter

Installation method: wall mount, Display: 20*2, alphanumeric, backlit LCD; Flow range: +/- 0 to 40 ft/s (+/- 0 to 12 m/s); Keypad: 16 touch keys (4*4); Output: 0/4-20mA DC, OCT, relay (SPST), frequency, Power supply: 90- 250VAC, 48 to 63 Hz and 10 to 36VDC; Accuracy 0.5% of reading, Repeatability 0.5% of reading; Pipes 1" to 200" (25mm to 5000mm); Two analog RTD inputs available, Energy monitoring software (Kjoules or BTU), 1G SD card high memory data logging, maximum memory 512 days of data, Transducer hazard area classification: Ex d II BT4 (Not ATEX or IECEx approved)

DIGITAL OUTPUTS

- 1** RS 232--also 0/4-20mA DC, OCT (Open Collector Transistor), relay (SPST), frequency.
- 2** RS-485, 4-20mA, OCT pulse output, relay output, (No RS- 232)
- E** 4-20mA, OCT pulse output, relay output, GPRS wireless module (no SIM card or software, no high capacity data logging)

ENCLOSURE

- 1** NEMA 4X (IP 65). Die-cast aluminum machined enclosure.
- 2** Explosion-proof enclosure , Exd II BT4 (not Agency approved)

TRANSDUCER

- S** Clamp on transducer, operating temperature: -40C to 100C (-40F to 212F)
- W** Insertion transducer, operating temperature: -40C to 100C (-40F to 212F)
Max operating pressure 20 barg, 300 psig
- WS** Insertion transducer (small), operating temperature: -40F to 176F (40C to 80C)
Max operating pressure 20 barg, 300 psig
use for pipe sizes below 16" (DN 400) if desired (3/4" insertion diameter)
- W** Insertion high-temperature transducer, operating temperature: -40F to 300F (-40C to 150C)
Max operating pressure 20 barg, 300 psig

Note: Insertion transducers include ball valves (1.5" brass), installation seat (carbon steel) for ball valve, mounting kit

CABLE LENGTH

- 30** 30ft (9m) Standard cable length
- 50** 50ft (15m) Standard cable length
- 100** 100ft (30m) Standard cable length
- 150** 150ft (45m) Standard cable length
- 200** 200ft (60m) Standard cable length
- 300** 300ft (90m) Standard cable length

Note: All transducers come with 30 ft (9m) of cable standard. Prices above represent additional charge for extra length. (cable = \$2.00 per foot)

OPTION: NIST TRACEABLE

- NIST** 5 Point Calibration Certification traceable to NIST